



kitchen think

Instructions for Installation and Use

**Gas Hob
Models G310 and G320X**

To the Installer

**Before installation fill in the product details on the back cover of this book.
The information can be found on the rating plate.**

To the User

**You must read the instructions prior to installing and using the appliance and
then retain them for future reference.**

CONTENTS

Introduction	3
For Your Safety	4
Know your Hob	5
How to use your Hob	5
Practical Advice	6
Care and Cleaning	7
Troubleshooting	7
Installation	8
Electrical Connection	9
User Characteristics	9
After Sales Service	10
Hotpoint Guarantee	11
Key Contacts	Back Cover

Retention of this Instruction Book

This Instruction Book must be kept handy for reference as it contains important details on the safe and proper use of the appliance.

If you sell or pass the appliance to someone else, or move house and leave it behind, make sure this Book is also provided so the new owner can become familiar with the appliance and safety warnings.

If the Book is lost or damaged a copy may be obtained from:
GDA LTD., Morley Way, Peterborough, PE2 9JB

Introduction

Your new hob is guaranteed* and will give lasting service. This guarantee is only applicable if the appliance has been installed in accordance with the installation instructions detailed in this booklet.

To help make best use of your cooking equipment, please read this booklet carefully.

The hob is designed specifically for domestic use and responsibility will not be accepted for use in any other installation.

*** The guarantee is subject to the provisions that the appliance:**

- (a) Has been used solely in accordance with this booklet.**
- (b) Has been properly connected to a suitable supply voltage as stated on the rating plate, attached to the appliance.**
- (c) Has not been subjected to misuse or accident or been modified or repaired by any person other than the manufacturers authorised employee or agent.**
- (d) Has been correctly installed.**



This appliance conforms with the following European Economic Community directives

- 73/23/EEC of 19/02/73 (Low Voltage) and subsequent modifications.
- 89/336/EEC of 03/05/89 (Electromagnetic Compatibility) and subsequent modifications.
- 93/68/EEC of 22/07/93 and subsequent modifications.

For Your Safety

When used properly your appliance is completely safe but as with any gas product there are certain precautions that must be observed.

PLEASE READ THE BELOW PRECAUTIONS BEFORE USING YOUR APPLIANCE.

To maintain the efficiency and safety of this appliance, we recommend you do the following:

- only call the Service Centres authorised by the manufacturer.
- always use genuine spare parts.

ALWAYS:

- make sure you remove all packaging and dispose of safely.
- check the soundness of the appliance after it has been unpacked.
- make sure you understand the controls before using the appliance.
- keep children away from the appliance during use.
- take care to avoid heat/steam burns when operating the controls.
- make sure the controls are turned off when you have finished cooking and when not in use.
- take care to avoid heat/steam burns when operating the controls.
- disconnect from the power supply, and allow to cool, before cleaning or performing maintenance.
- refer servicing to a qualified appliance service engineer.
- keep the hob clean as a build up of grease or fat from cooking can cause a fire.
- follow the basic principles of food handling and hygiene to prevent the possibility of bacterial growth.
- dry food thoroughly before frying and lower it slowly into the hot oil or fat. Frozen food in particular, will cause frothing and spitting if added too quickly.
- keep outside of pans clean and free from streaks of oil or fat.
- place pans centrally over the burner making sure handles are kept away from the edge of the hob and cannot be heated by other burners/pans.
- keep any ventilation slots clear of obstructions.

NEVER:

- attempt to install or repair the appliance without the assistance of qualified personnel.
- store items above the appliance that children may attempt to reach.
- heat up unopened food containers, as pressure can build up causing the container to burst.
- use the appliance to heat up anything other than food.
- use the appliance as a room heater.
- dry any items on the hob.
- install the appliance next to curtains or other soft furnishings.
- allow children to play with or tamper with the controls.
- leave children unsupervised where cooking appliances are installed as all the cooking surfaces get hot during and after use.
- store chemicals, foodstuffs or pressurised containers in or on the appliance, or in cabinets immediately above or next to the appliance.
- use flammable or plastic items on or near the hob.
- use adapters, multiple sockets and/or extension leads.
- fill a deep fat frying pan more than 1/3 full of oil, or use a lid. **DO NOT LEAVE UNATTENDED WHILE COOKING.**
- fry too much food at a time, especially frozen food. This only lowers the temperature or the oil or fat too much, resulting in greasy food.
- pull on the appliance or the supply cable to unplug it from the electrical outlet.
- allow power cables of other appliances to come into contact with hot parts of this appliance.
- expose the appliance to atmospheric agents, such as rain or sunlight.
- operate the appliance with wet hands.
- allow anyone to sit or stand on any part of the appliance.
- use misshapen pans which may be unstable.
- use round base woks directly on the pan supports.
- use fish kettles or large preserving pans across two burners.
- operate the appliance with wet parts of the body.
- operate the appliance when barefoot.

SAFETY ADVICE

IMPORTANT - As with any cooking appliance there could be some fire risk attached to the heating of oil, particularly for deep fat frying. Cooking utensils containing oil must not be left unattended (eg. to answer the telephone) on or in close proximity to the cooking areas.

IN THE EVENT OF A CHIP PAN OR ANY OTHER PAN FIRE:

1. Turn off the burners.
2. Cover the pan with a fire blanket or damp cloth, this will smother the flames and extinguish the fire.
3. Leave the pan to cool for at least 60 minutes before moving it. Injuries are often caused by picking up a hot pan and rushing outside with it.

NEVER USE A FIRE EXTINGUISHER TO PUT OUT A PAN FIRE as the force of the extinguisher is likely to tip the pan over. Never use water to extinguish oil or fat fires.

Know your Hob

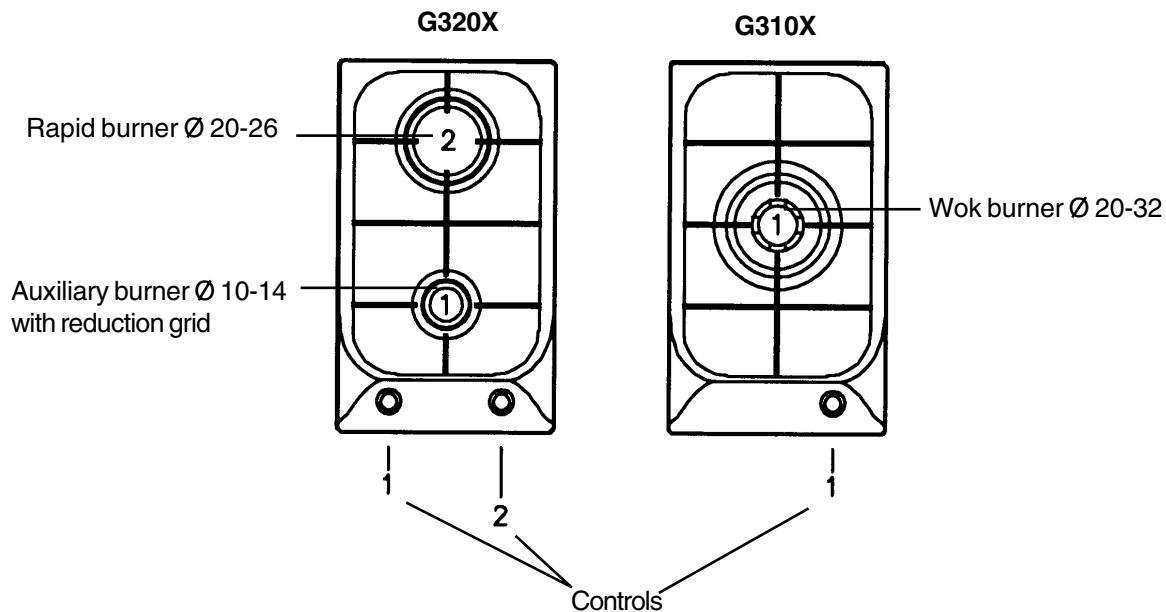

How To Use Your Hob

To turn on a cooking area, select the desired cooking area. Then turn the corresponding control anti-clockwise until the pointer is set to the maximum setting. Keep the control pressed in for approximately 3 seconds. When you release the control check that the burner stays lit.

Then adjust the flame to the required setting. Full anti-clockwise position sets the burner to minimum.

To turn off the cooking area, return the control to 0 and the cooking area is turned off.

Practical Advice

Using the burners

To obtain maximum efficiency from the burners, it is advisable to use only pans with a diameter that is suitable for the burner, so that the flame does not extend beyond the pan base (see following table).

Burner	Diameter of the pan (in cm)
A. Auxiliary	from 6 to 14
B. Semi-rapid	from 15 to 20
C. Rapid	from 21 to 30
D. Triple ring	from 24 to 30

To obtain the best results with the hob, several fundamental rules should be followed while cooking or preparing food.

- Use cookware with a flat bottom to make certain that the pot sets properly on the cooking area.

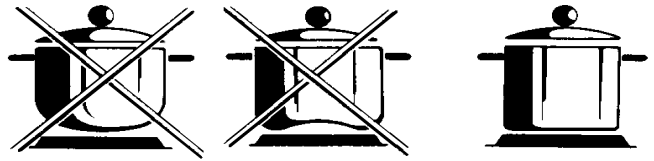

When a liquid starts boiling, it is advisable to turn the flame down just enough to keep the liquid simmering.

Burner	Diameter of Pan
Rapid	20 - 26
Auxiliary	10 - 14
Wok	20 - 32

Care and Cleaning

Before cleaning or performing maintenance on your hob, disconnect it from the power supply.

To extend the life of the hob, it should be cleaned carefully and thoroughly on a frequent basis, keeping in mind the following:

- The enameled parts must be washed with warm water without using abrasive powders or corrosive substances which could ruin them.
- The removable parts of the burners should be washed frequently with warm water and soap, making sure to remove caked-on substances.
- On hobs with automatic ignition, the end of the electronic ignition device must be cleaned carefully and frequently, making sure that the gas holes are not clogged.

- Stainless steel can be stained if it remains in contact with highly calcareous water or aggressive detergents (containing phosphorous) for an extended period of time. It is recommended that these parts be rinsed thoroughly with water and then dried well. It is also a good idea to clean up any spills.

Greasing the Gas Valves

Over time, the gas valves may stick or become difficult to turn. If this is the case, they must be cleaned on the inside and then regreased.

N.B.: This procedure must be performed by a technician authorized by the manufacturer.

Troubleshooting

Before calling service for assistance, check through the following list, there may be nothing wrong.

First of all, check to see that there are no interruptions in the gas and electrical supplies, and, in particular, that the gas valves for the mains are open.

If the burner does not light or the flame is not uniform around the burner.

Check to make sure that:

- The gas holes on the burner are not clogged;
- All of the movable parts that make up the burner are mounted correctly;
- There are no draughts around the cooking surface.

If the flame does not stay lit.

Check to make sure that:

- You press the knob all the way in;
- You keep the knob pressed in long enough to activate the flame failure device.
- The gas holes are not clogged in the area corresponding to the flame failure device.

If the burner does not remain on when set to "Low".

Check to make sure that:

- The gas holes are not clogged.
- There are no draughts near the cooking surface.
- The minimum has been adjusted correctly (see Installation section, "Minimum Regulation").

If the cookware is not stable.

Check to make sure that:

- The bottom of the cookware is perfectly flat.
- The cookware is centered correctly on the burner.
- The support grids have not been inverted.

If, despite all of these checks, the hob does not function properly and the problem persists, call Hotpoint Service (see KEY CONTACTS, back page), informing them of:

- The type of problem.
- The abbreviation used to identify the model (Mod. ...) as indicated on the warranty.

IMPORTANT:

Never call upon technicians not authorized by the manufacturer, and refuse to accept spare parts that are not original.

Installation

These instructions are intended for the qualified technician installing the appliance in order to insure that the installation, adjustments and maintenance procedures are performed correctly and comply with the regulations currently in effect. **Important: the hob must be disconnected from the power supply before making any adjustments or performing any maintenance, etc.**

The gas hob is not provided with a combustion product discharge. It must be installed in a sufficiently ventilated space, in terms of the laws in force. The amount of air which is necessary for combustion must not be below 2.0m³/h for each kW of installed power. The gas hob can be fitted into a worktop as illustrated below.

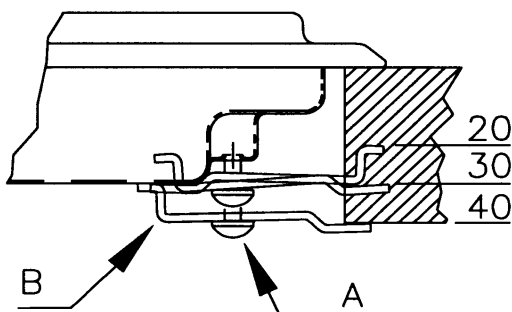
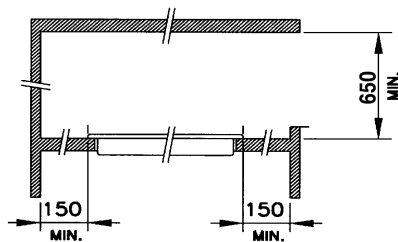
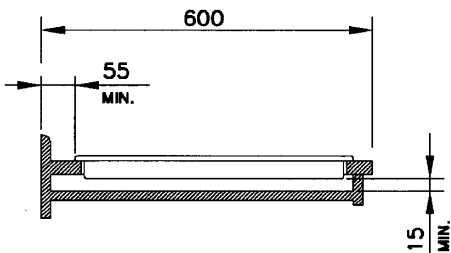
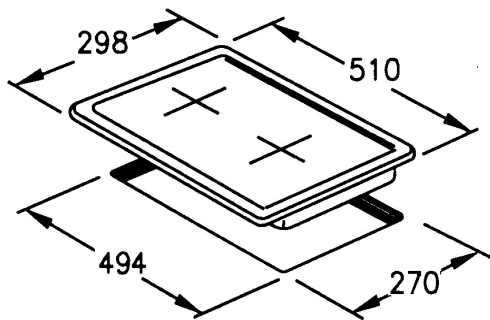

DO NOT overtighten screw 'A', one turn maximum will be sufficient, after correctly fitting shaft 'B' into place (as shown above). Ensure that the supporting surface is perfectly even. Fit the appropriate expanded seal. The hob must not be subjected to strains caused by uneven supporting surfaces.

These measurements must absolutely be observed in so far as improper installation can cause the surrounding surface areas to overheat. It is recommended that the hob be installed at a distance of at least 55mm from the back wall or other vertical surfaces to ensure that the air circulates properly over the cooking area and to avoid overheating the surrounding surfaces. A seal or gasket is provided with the hob, make sure that it adheres properly to the bottom part of the frame of the hob. **The seal must fit properly around the entire hob frame and especially along the corners in order to create a seal between the work top and the hob itself so as to prevent spills or splashes from leaking into the cabinet below.**

The hob must be fixed into the worktop using the fixing clamps (see diagram).

It is essential to install the hob on a totally flat surface. Any damage caused by incorrect fitting may alter the characteristics or impair performance.

Insert the hob into the hole, pressing firmly around the frame to make it adhere to the counter top.

GAS CONNECTION:

Connect the hob to the gas cylinder or to the mains, according to the prescribed standards in force. Ensure beforehand that the hob is compatible to the type of gas available.

Otherwise refer to section: 'Adaptation to Various Types of Gas'.

Check that the feed pressure falls within the values described in the table: 'User Characteristics'.



Rigid or Semi-Rigid Metal Connection:

Carry out the connection with fittings and metal pipes (even flexible pipes) NB. When the installation is complete, check for perfect sealing of the entire system by using a soapy solution.

Adaptation to Various Types of Gas:

Should the hob be pre-set to a different type of gas to that required/available, proceed as follows:

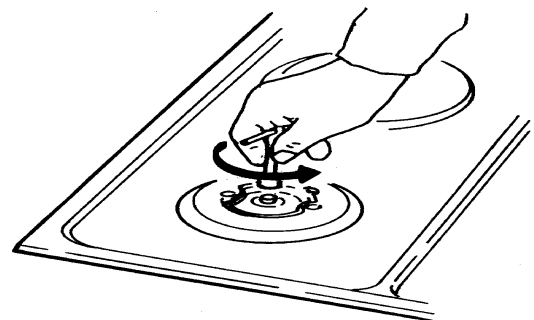

- replace the injectors with those for the type of gas to be used (see table: 'User Characteristics').

- to adjust to the minimum, use a screwdriver on the screw placed on the tap, after turning the tap to its minimum position. For LPG (butane/propane) screw tight.

Electrical Connection

Electrical Connection

THIS APPLIANCE MUST BE EARTHED.

The installation procedure must be carried out by a qualified electrician.

The electrical safety of this appliance is guaranteed only if the appliance is correctly earthed in compliance with the standards of electrical safety.

The manufacturer can under no circumstances be considered responsible for any damage that might occur due to incorrect earthing of the hob.

IMPORTANT POINTS:

Your hob is supplied with a special connection cable.

If ever the cable is damaged it should be replaced by an authorised service engineer only.

Disconnect the hob from the electrical supply before any work is carried out.

Connecting the supply cord to the electrical mains:

The hob must be connected to a double pole mains switch which must be installed between the appliance and the mains. The double pole mains switch must have a minimum of 3mm of space between the contacts, be sized to the load and comply with current regulations (the switch must not be able to disconnect the earth conductor).

The supply cord should conform to BS6004 conductor size 4mm² and must be positioned so that no part of it reaches a temperature of 50°C higher than room temperature.

Before making the connection, make sure that:

- the limiter switch (fuse) and the residual wiring can support the appliance load (see the rating plate, below).
- the mains system is properly earthed in compliance with current regulations and provisions.
- there is easy access to the socket or the double pole mains switch after the appliance is installed.
- the isolation switch must not be positioned directly above the hob.

IMPORTANT:

If the hob is installed above a built-in oven, the electrical connection for the hob must be independent of that for the oven, both for safety reasons and to facilitate the removal of the oven for maintenance, repair etc.

User Characteristics

TYPE	PRESSURE	BURNER	Ø INJECTORS	CAPACITY	CONSUMPTION
Natural Gas	G20 20 mbar	Rapid	116	3000W	286l/h
		Auxilliary	79	1000W	95l/h
		Wok	137	3600W	343l/h
LPG	G30/31 28-30/37 mbar	Rapid	86	3000W	218l/h
		Auxilliary	50	1000W	73l/h
		Wok	94	3600W	262l/h



After Sales Service

"No company is better positioned to offer an after sales service on a Hotpoint appliance than us - the manufacturer"

As part of our commitment to you, all Hotpoint appliances have the added benefit of a fully inclusive parts and labour guarantee for the first 12 months. In addition to this you also have the advantage of **free replacement parts for the first 5 years** when fitted by a Hotpoint engineer. When the 12 months parts and labour guarantee expires we offer the following after sales service options:

Repair Service and Information Help Desk

UK: 08709 066066

www.theservicecentre.co.uk

Republic of Ireland: 1850 302 200

Note: Our operators will require the Model number and the Serial number of your appliance

Available 364 days a year with a fast, effective and value for money service. We have the largest white goods repair service in the UK with over 1200 of our own fully trained engineers. All repairs include a parts and labour guarantee for 12 months from the date of the repair.

If you require any information or have any questions about your appliance, our operators are on hand with help and advice.

All this ensures that you will receive the best available after sales service possible.

Extended Warranties

UK: 08709 088 088

www.theservicecentre.co.uk

Republic of Ireland: 1850 502 200

Whether you have just one or a number of Hotpoint appliances in your kitchen, we offer two service cover plans to give you total peace of mind.

- Repair Protection Plan - FREE service repairs for a single Hotpoint appliance during the period of cover.
- Kitchen Cover - FREE service repairs for all your Hotpoint appliances less than 8 years old.

Genuine Parts and Accessories UK: 08709 077 077

www.theservicecentre.co.uk

Republic of Ireland: (01) 842 6836

A wide range of genuine parts and accessories are available from our hotline or through our web site.

Genuine parts and accessories, extended warranties and service repairs are all available on our web-site at:



www.theservicecentre.co.uk



Guarantee

"Satisfaction guaranteed or your money back"

We give you a unique 'satisfaction guaranteed' promise - **valid for 90 days** - after you have purchased your Hotpoint appliance. If there is a technical problem simply call Hotpoint Repair service or visit our web-site at www.theservicecentre.co.uk and where necessary, we will arrange for an engineer to call. If the technical problem is not resolved under this guarantee, **we will replace your machine or, if you prefer, give you your money back.**

All Hotpoint appliances carry a fully inclusive 12 month parts and labour guarantee as well as free replacement parts for the first 5 years (except microwaves, selected integrated appliances and cooker hoods, which have a one year guarantee) provided that they are fitted by a Hotpoint engineer.

Guarantee terms and conditions

Your guarantee is only applicable in the United Kingdom or Republic of Ireland and is subject to the following provisions that your appliance:

- Has been installed and used correctly in accordance with this instruction booklet.
- Has been used solely for domestic purposes and is located on domestic premises (ie. not for commercial or trade use).
- Has been properly connected to a suitable electrical supply voltage as stated on the appliance rating plate.
- Has not been subject to misuse, accident, modified or repaired by anyone other than one of our own service engineers.

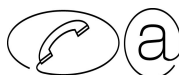

For pre purchase information on any other Hotpoint product call: 08701 50 60 70
or visit: www.hotpoint.co.uk

Recycling & Disposal Information

As part of Hotpoint's continued commitment to helping the environment, Hotpoint reserves the right to use quality recycled components to keep down customer costs and minimise material wastage.

Please dispose of packaging and old appliances carefully.

To minimise risk of injury to children, remove the plug and cut mains cable off flush with the appliance. Dispose of these parts separately to ensure that the appliance can no longer be plugged into a mains socket.



Key Contacts

After Sales Service

Over 1200 trained specialists, directly employed by us, ensure that you can have complete confidence in both the appliances and services we offer.



Repair Service and Information Desk

UK: 08709 066 066

(Open 8 to 8 Mon - Fri, 8 to 6 Sat, 10 to 4 Sun & Bank Holidays)

www.theservicecentre.co.uk

Republic of Ireland: 1850 302 200

Note: Our operators will require the following information:

Model number:

Serial number:

Extended Warranties

UK: 08709 088 088

(Open 8 to 8 Mon - Sun)

www.theservicecentre.co.uk

Republic of Ireland: 1850 502 200

Genuine Parts and Accessories

UK: 08709 077 077

(Open 8-30 to 5-30 Mon - Fri & 9 to 12 Sat)

www.theservicecentre.co.uk

Republic of Ireland: (01) 842 6836